

FIBER OPTIC 1xN SWITCH

coaxial design

OVERVIEW

Sercalo's fiber optic 1xN switches are bidirectional opto-mechanical switches based on a coaxial design where an electrostatic MEMS mirror redirects light from a common fiber to one of N ports. The MEMS technology results in low insertion loss and low crosstalk between channels while keeping a constant switching performance over life.

The hermetically sealed MEMS and the laser welded fiber assembly perform over a broad temperature range and guarantee superior long-term stability. No epoxy is present in the optical path. The miniature packages are well suited for direct mounting on printed circuit boards.

The switch is available in several different variants to simplify integration in existing systems. The switch engine stays the same, only the driver card is adapted. The component is compliant with Telcordia 1221 reliability standards and RoHS requirements 2015/863/EU.

FEATURES

- Low insertion loss
- Reliable
- Up to 1x48 optical ports
- UART, I²C/SMBus and parallel interface
- Ethernet interface available on request
- RoHS compliant

APPLICATIONS

- Optical network switching
- Instrumentation
- Test and measurement

Contact:

Sercalo Microtechnology Ltd.
Landstrasse 151
9494 Schaan - Principality of Liechtenstein
Tel. +423 237 57 97 Fax. +423 237 57 48
www.sercalo.com e-mail: info@sercalo.com

ORDERING INFORMATION

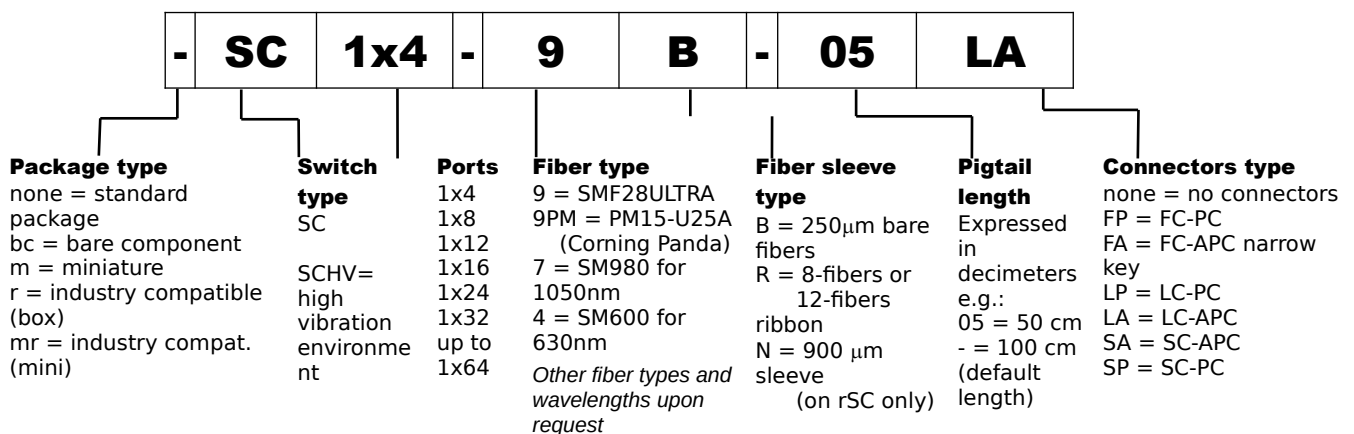

TECHNICAL SPECIFICATIONS

	Unit	Min	Typ	Max
Optical Specifications				
Wavelength range	nm	1250		1670
Insertion loss up to 1x4 ¹	dB		0.4	1.0
Insertion loss up to 1x16 ¹	dB		0.8	1.2
Insertion loss up to 1x24 ¹	dB		1.0	1.5
Insertion loss up to 1x36 ¹	dB		1.2	2.0
Insertion loss up to 1x64 ¹	dB		1.2	2.0
Crosstalk	dB	50	60	
Directivity ²	dB	30		
Polarization dependent loss	dB			0.1
Return loss	dB	50	55	
Wavelength dependent loss (one band)	dB			0.2
Wavelength dependent loss (1250–1670 nm)	dB		0.5	1.0
Temperature dependent loss	dB			0.3
Maximum optical power level ³	mW			500
Switching time	ms		5	10
Cycle rate	Hz		10	50
Repeatability ⁴	dB			0.01
Durability	cycles		No wear out	
Optical Specifications (PM fiber - up to 1x4)				
Polarization extinction ratio	dB	20		
Electrical Specifications (SC, mSC, rSC, mrSC)				
Supply voltage	V	4.75	5	5.25
Power consumption, normal mode	mW			150
Power consumption, standby	mW		40	
UART speed	baud	9600		115200
SMBus/I ² C bus speed	kbps			400
Input logic level low	V		0	0.6
Input logic level high	V	2.4	5	
Output logic level low	V		0	0.6
Output logic level high	V	2.6	3.3	
Reset inactive voltage ⁵	V	2.4	5	
Reset active voltage	V		0	0.9
Reset pulse duration	ms	15		
Electrical Specifications (bcSC)				
Driving voltage	V	0		42
Driving voltage damage threshold	V			45
Electrostatic discharge tolerance ⁶	V			50
Package				
Operating temperature	°C	-10		70
Storage temperature	°C	-40		85
Operation humidity (non condensing)	% r.h.	0		95
Pigtail length	cm	50		100
Dimensions	SC	mm	40 x 21 x 7	
	mSC	mm	40 x 7 x 7.5	
	rSC	mm	68 x 30 x 9	
	mrSC	mm	38 x 16 x 9	
	bcSC	mm	6 x 35	
ROHS Compliance		2015/863/EU (no exceptions)		

¹ Values at 25 °C at 1550 nm, without connectors. For operation over several bands between 1250 to 1670 add 0.5 dB.

² Directivity is specified for port counts up to 16. For switches with port counts higher than 16 directivity may be degraded.

³ It is recommended to turn off the laser during switch transients when switching optical power above 500 mW.

⁴ For constant temperature and polarization.

⁵ Through onboard pull-up resistor.

⁶ The bare optical component is not protected against ESD.

Sercalo's COAXIAL TYPE 1xN switch is non-latching: at power-off it breaks the optical connection and routing of the common port is not defined. The component is bidirectional, the com port can be used as input or output. The **PM Panda** version is offered up to 1x4 ports. The switch is available in five different variants:

- SC:** standard size – colored bare fibers or ribbon fibers
- mSC:** miniature size – small driver board: 7x40 mm
- rSC:** compatible with industry pinout
- mrSC:** mini variant: industry compatible pinout – without metal box
- bcSC:** bare optical component

FUNCTIONAL BLOC DIAGRAM

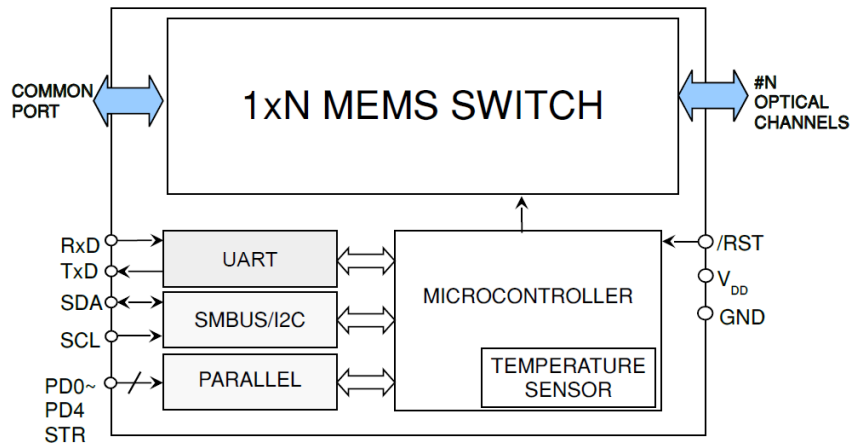

SC1xN “STANDARD SIZE” – DIMENSIONS AND PINOUT

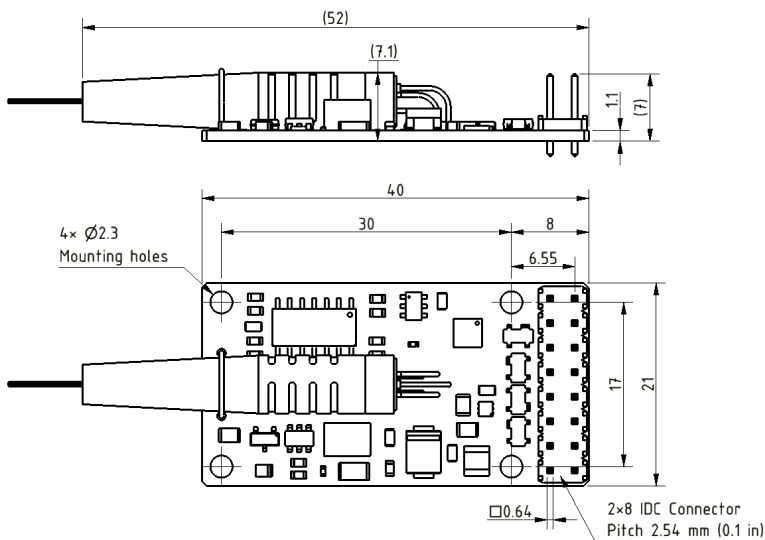

Pin	Description
1	Parallel PD3
2	Parallel PD4
3	Parallel PD1
4	Parallel PD2
5	Parallel STROBE/ENABLE
6	Parallel PD0
7	Ground (GND)
8	Supply voltage (V _{DD})
9	Reserved
10	UART TX
11	Reserved
12	UART RX
13	System reset (RST)
14	SMBus/I ² C SDA
15	SMBus/I ² C SCL
16	Ground (GND)

mSC1xN “MINIATURE” – DIMENSIONS AND PINOUT

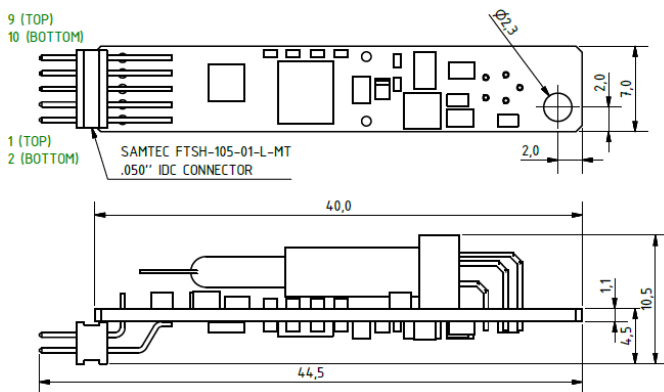

Pin	Description
1	I/F mode
2	Supply voltage (V _{DD})
3	System reset (RST)
4	Ground (GND)
5	SMBus/I ² C A0
6	SMBus/I ² C A2 / UART RX
7	SMBus/I ² C A1 / UART TX
8	SMBus/I ² C SCL
9	SMBus/I ² C A3
10	SMBus/I ² C SDA

rSC1xN “INDUSTRY COMPATIBLE” – DIMENSIONS AND PINOUT

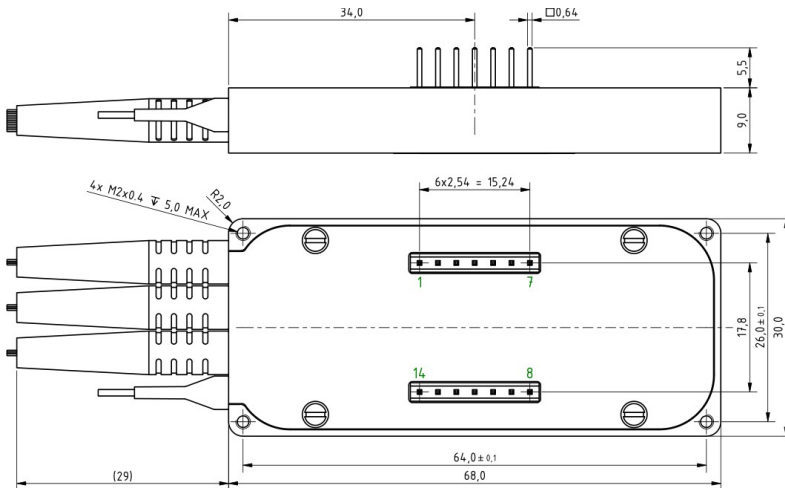

Pin	Description
1	I/F mode 1
2	Supply voltage (V _{DD})
3	Parallel strobe
4	Ground (GND)
5	Parallel D0 / SMBus/I ² C A0
6	SMBus/I ² C SDA / UART TX
7	SMBus/I ² C SCL / UART RX
8	I/F mode 0
9	Parallel D2 / SMBus/I ² C A2
10	Done
11	Ground (GND)
12	Parallel D1 / SMBus/I ² C A1
13	Parallel D3 / SMBus/I ² C A3
14	System reset (RST)

mrSC1xN “MINI SIZE INDUSTRY COMPATIBLE” – DIMENSIONS AND PINOUT

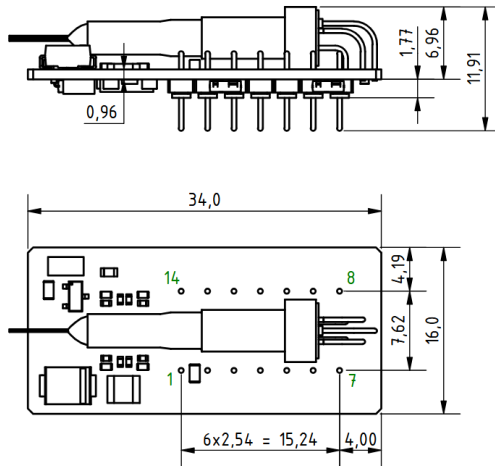

Pin	Description
1	NC
2	Supply voltage (V _{DD})
3	Parallel strobe
4	Ground (GND)
5	Parallel D0
6	Parallel D1 / I ² C SDA
7	Parallel D2 / I ² C SCL
8	I/F mode
9	Parallel D4 / UART TX
10	Parallel D5 / UART RX
11	Ground (GND)
12	DONE
13	Parallel D3 / mode
14	System reset (RST)

bcSC “BARE OPTICAL COMPONENT” – DIMENSIONS AND PINOUT

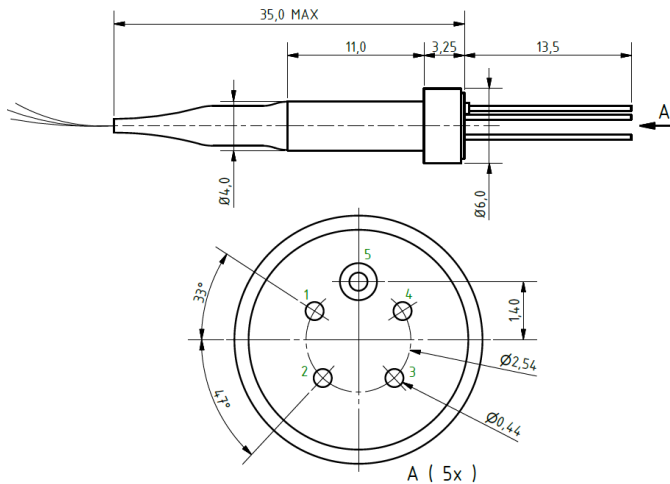

Pin number	Description
1	Axis X-
2	Axis Y-
3	Axis X+
4	Axis Y+
5	Common

INSERTION LOSS vs. TEMPERATURE (SC 1x8)

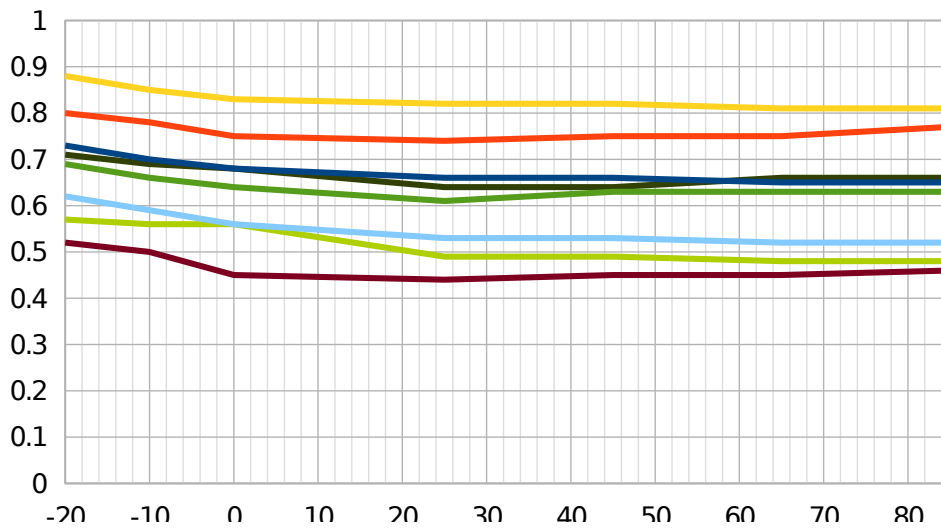

WAVELENGTH DEPENDENT LOSS (SC 1x4)

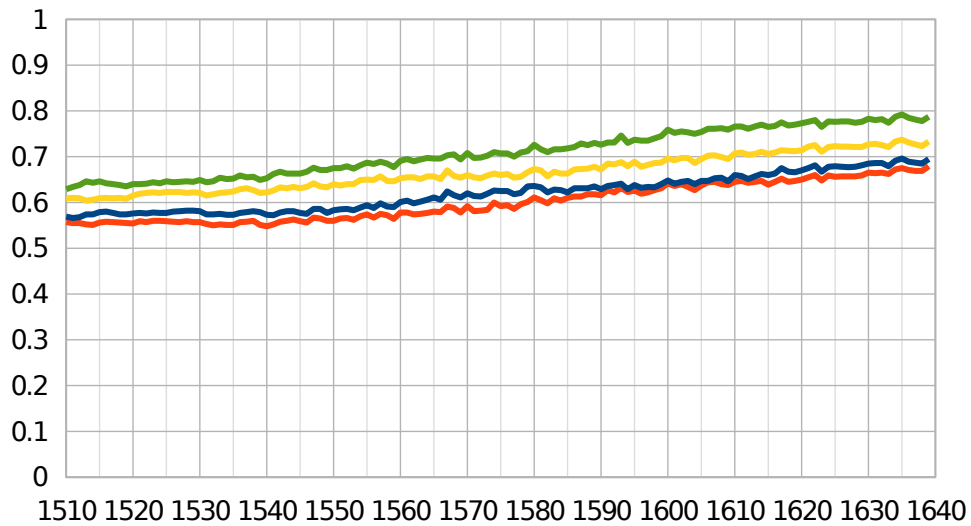

OPTICAL RESPONSE TIME

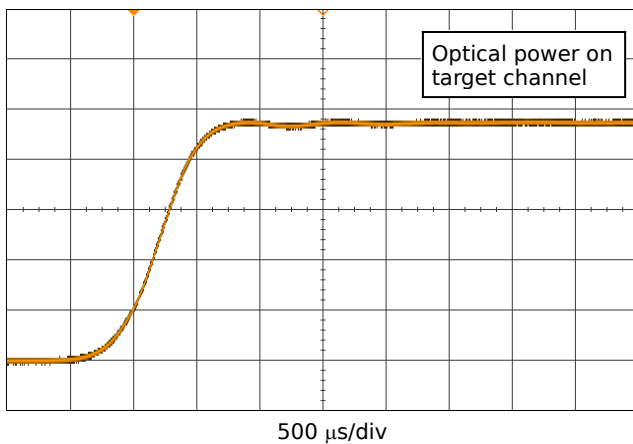

CONTINUOUS SWITCH OPERATION

