

MINIATURE FIBER OPTIC MEMS SWITCH

(multimode fibres)

OVERVIEW

The **Sercalo** sx series are miniature opto-mechanical switches for fiber optic communication systems and submodules. The switch is available in latching or non-latching variants, with 1x1, 2x1 or 2x2 architecture. The switch offers very small size, ease of integration and the established solid state reliability of Sercalo's MEMS components.

The plastic package is one of the smallest in the industry. It is optimized for low cost production while maintaining highest reliability comparable to a solid state device. The component is designed to exceed Telcordia 1221 quality standards.

FEATURES

- 23 x 10 x 6 mm size
- Low Cost
- TTL or CMOS logic
- latching or non-latching
- 2x2, 2x1, 1x1 variants
- single or multimode

APPLICATIONS

- Protection Switching
- Reconfiguration
- Optical Subsystems
- Array integration

Contact:

Sercalo microtechnology ltd
Landstrasse 151, 9494 Schaan
Principality of Liechtenstein
Tel. +423 237 57 97 Fax. +423 237 57 48
www.sercalo.com e-mail: info@sercalo.com

DESCRIPTION

The **Sercalo** sx switches are composed of an optical subsystem and an electrical driver interface. The optical switching function is realised by a silicon MEMS chip, on which a mirror can be moved in and out of the optical path by electrostatic actuation. In the latching *SXL* variants a bistable suspension mechanism keeps the last selected state in power off. In the non-latching *SXN* variants the switch returns into the bar state when electrical power is removed.

To operate the switch 5V and 0V are applied on pins 1 and 2, which are used by the DC-DC converter of the internal driver to supply a high voltage for the actuator control. CMOS or TTL logic levels on pins 3-4 control the high voltage on the electrostatic actuator.

To set the switch state in the *latching variant*, pin 3 respectively pin 4 are set to logic high (5V) for 10 ms and the corresponding switch state is selected. At rest pins 3 and 4 should be pulled to 0 V and must not be floating.

In the *non-latching variant* only pin 3 is used to set the state of the switch. To set the cross state pin 3 must be at logic high. When pin 3 goes to logic low, or at power off, the switch returns into the bar state.

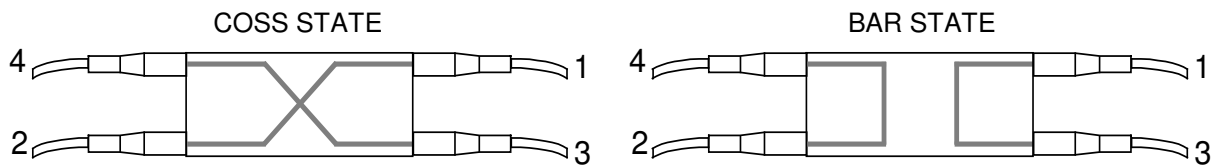

TECHNICAL SPECIFICATIONS (for Multi mode fibres)

	Unit	Min	Typ	Max
Switch				
Wavelength Range	nm	600		1700
Insertion Loss (measured at 1300 nm)	dB		0.4	1.2
Crosstalk	dB		60	40
Return Loss	dB		40	30
Repeatability ¹	dB			0.005
Switching Time	ms		2	20
Durability	cycles		10 ⁹	
Integrated Driver				
Supply Voltage <i>Vcc</i> (pin 1)	V	3.2	3.3 or 5	5.25
Current Consumption <i>Icc</i> (pin 1)	mA		1	45
Logic Level Low (pins 3, 4)	V			0.3
Logic Level High (pins 3, 4)	V	3.0		
Selection Pulse Width	ms	2	10	
Package				
Operation Temperature	°C	0		70
Storage Temperature	°C	-40		70
Size (L x W x H)	mm		23.2 x 10.1 x 5.9	

ORDERING INFORMATION

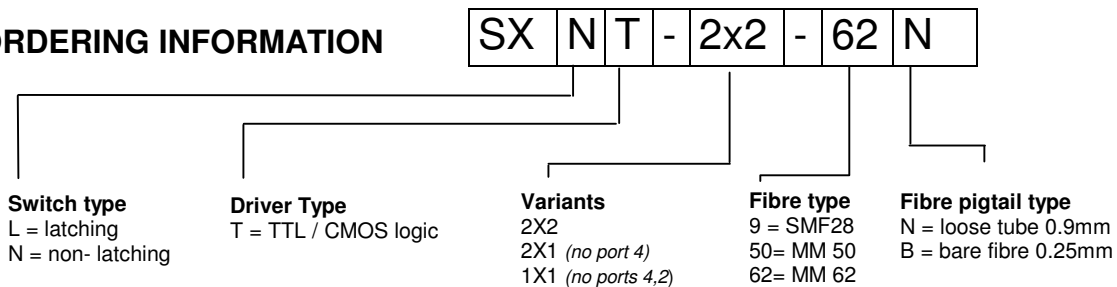

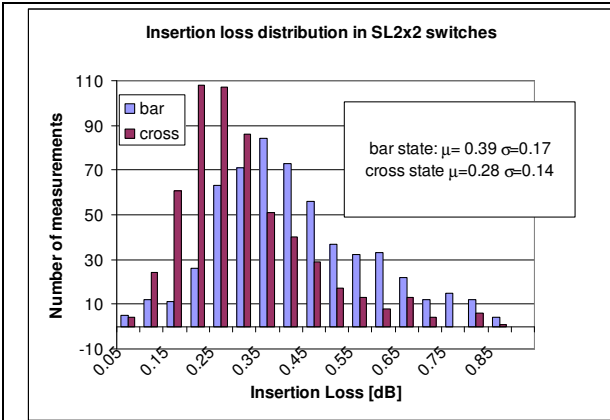

Figure 1: Insertion loss distribution

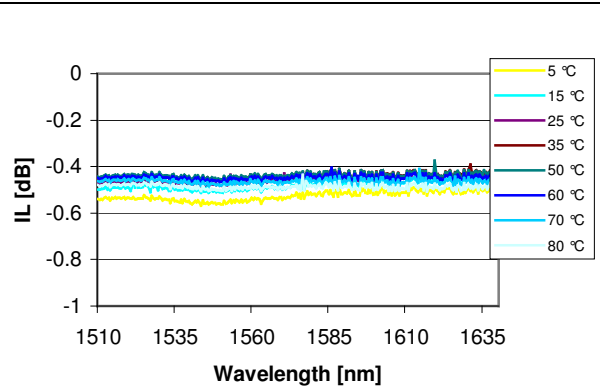

Figure 2: spectral response over temperature

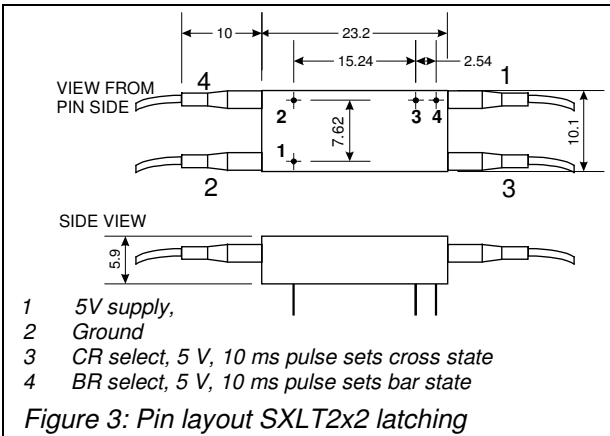

Figure 3: Pin layout SXLT2x2 latching

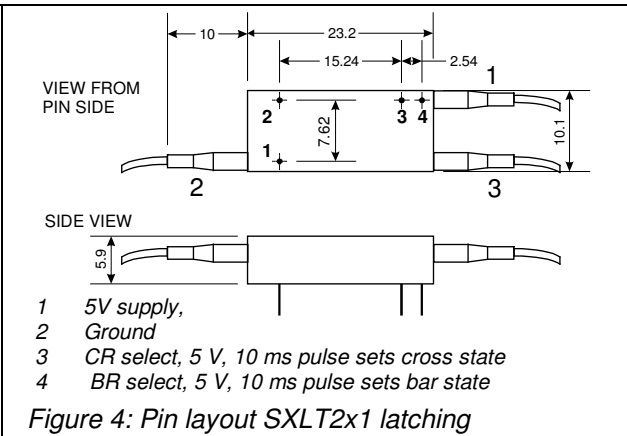

Figure 4: Pin layout SXLT2x1 latching

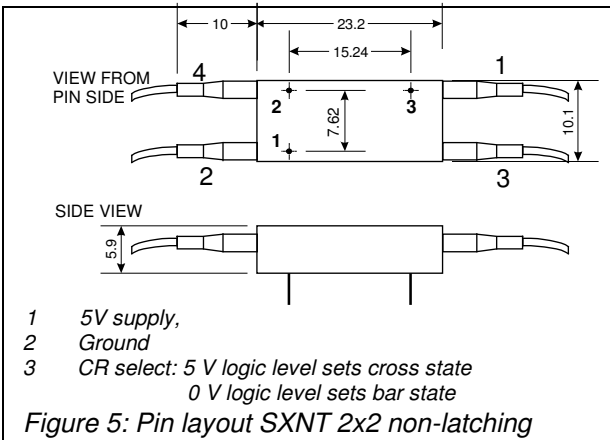

Figure 5: Pin layout SXNT 2x2 non-latching

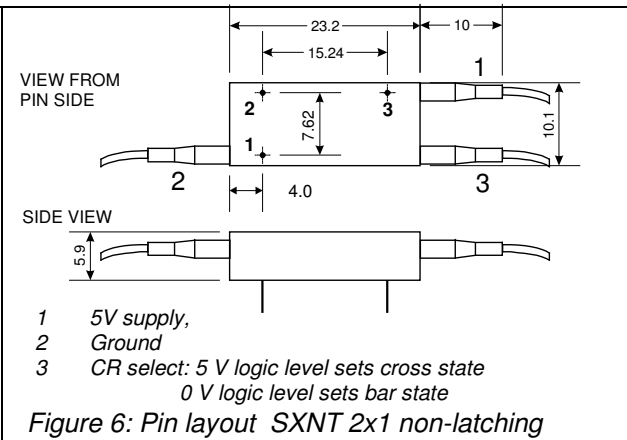

Figure 6: Pin layout SXNT 2x1 non-latching

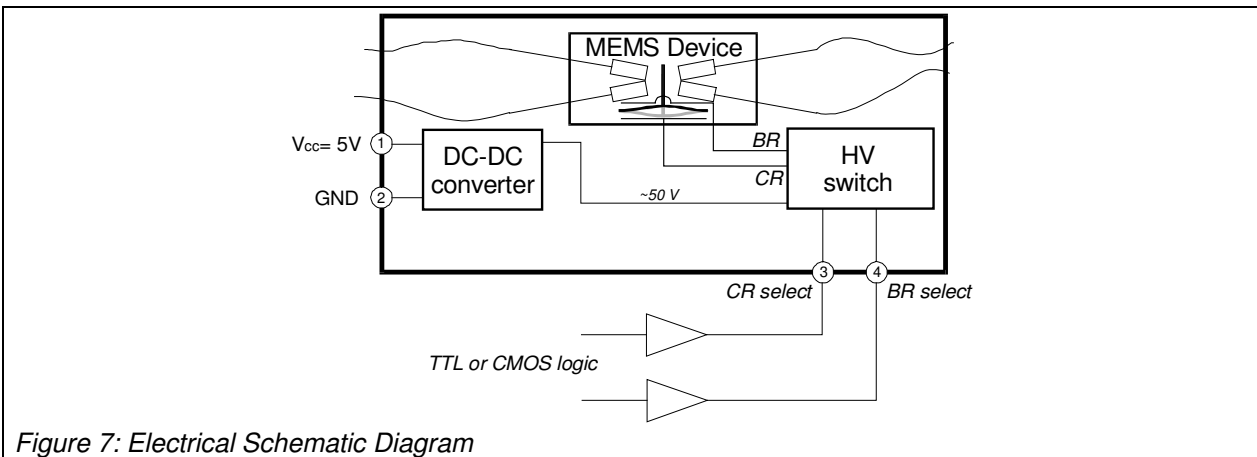

Figure 7: Electrical Schematic Diagram