

## **MULTIMODE FIBER OPTIC 1x2 SWITCH**

### **OVERVIEW**

The **sercalo** sw switches are very fast optomechanical switches based on the MEMS technology. The component is designed for optical switching in multimode fiber networks and is available in 2x1, 2x2, 1x4 and 1x8 variants. The highly reliable switching mechanism uses an integrated micromirror and features fast switching time below 4 ms and below 0.9 dB insertion loss.

The miniature package withstands rugged environments and is well suited for direct mounting on printed circuit boards. The switch is qualified according to Telcordia GR 1221.

### **APPLICATIONS**

- Optical Reconfiguration
- Protection Switching
- Instrumentation

#### **ORDERING INFORMATION**

SW2x1-62n-07-17 (62  $\mu$ m core fiber)  
SW2x1-50n-07-17 (50  $\mu$ m core fiber)

### **FEATURES**

- reliable
- 0.5 dB insertion loss
- 2 ms response time
- 50 dB crosstalk
- miniature size
- 62.5 or 50  $\mu$ m GI fiber
- non-latching

#### **Contact:**

Sercalo microtechnology ltd  
Landstrasse 151, 9494 Schaan  
Principality of Liechtenstein  
Tel. +423 237 57 97 Fax. +423 237 57 48  
www.sercalo.com e-mail: info@sercalo.com

## DESCRIPTION

The **sercalo** non-latching sw switch modules are fast and reliable switches designed for single mode and multimode fiber communication networks. The device is based on the latest silicon technology and uses a micro-mechanical mirror to switch light. Operated by an electrostatic actuator, the switch features fast switching and high crosstalk attenuation above 50 dB. The switch is powered by a 5 V supply voltage. A 5 V TTL or CMOS drive signal is used to control the switching state.

With 0 V on the drive pin (No 2) the switch is in its bar state. When 5 V are applied to the drive pin, the micromirror is moved out of the optical path, which puts the switch into its cross state. At power off, i.e. when either the supply voltage or the drive signal falls to 0 V, the switch returns into its bar state. The switching mechanism offers the reliability of a solid state device; it neither wears out nor degrades over time. Even after billions of cycles the switching quality stays constant.

### TECHNICAL SPECIFICATIONS (*Multimode Variant*)

	Unit	Min	Typ	Max
<b>Switch</b>				
Wavelength Range	nm	700		1700
Insertion Loss	dB		0.4	1.0
Crosstalk	dB		55	45
Backreflection	dB		45	35
Polarisation Dependent Loss	dB		0.04	0.10
Repeatability	dB			0.001
Switching Time	ms		2	20
Fiber Pigtail	µm		62.5/125/900 or 50/125/900	
Durability	cycles		no wear out	
<b>Package</b>				
Supply Voltage	V	4.0	5	5.25
Power Consumption	mW		5	40
Operation Temperature	°C	0		70
Storage Temperature	°C	-40		85
Size (L x W x H)	mm		45 x 24 x 9.5	

### PIN CONNECTIONS

- 1 Supply 5 V
- 2 Drive Signal 5 V TTL
- 3 Ground 0 V

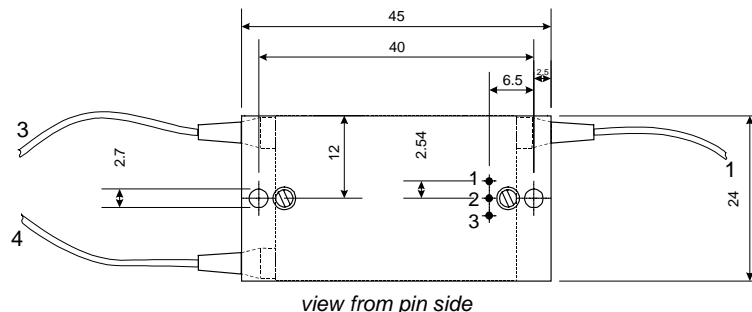

### ORDERING INFORMATION

SW2x1-62n-07-17 (62.5 µm core fiber)  
SW2x1-50n-07-17 (50 µm core fiber)

### Contact:

Sercalo microtechnology ltd  
Landstrasse 151, 9494 Schaan  
Principality of Liechtenstein  
Tel. +423 237 57 97 Fax. +423 237 57 48  
www.sercalo.com e-mail: info@sercalo.com

**sercalo**